

CASTERED BEDROOM PLATFORM IS PRESET FOR START OF SHOW
ROLLS OFFSTAGE IN SCENE CHANGE AT THE END OF ACT 1

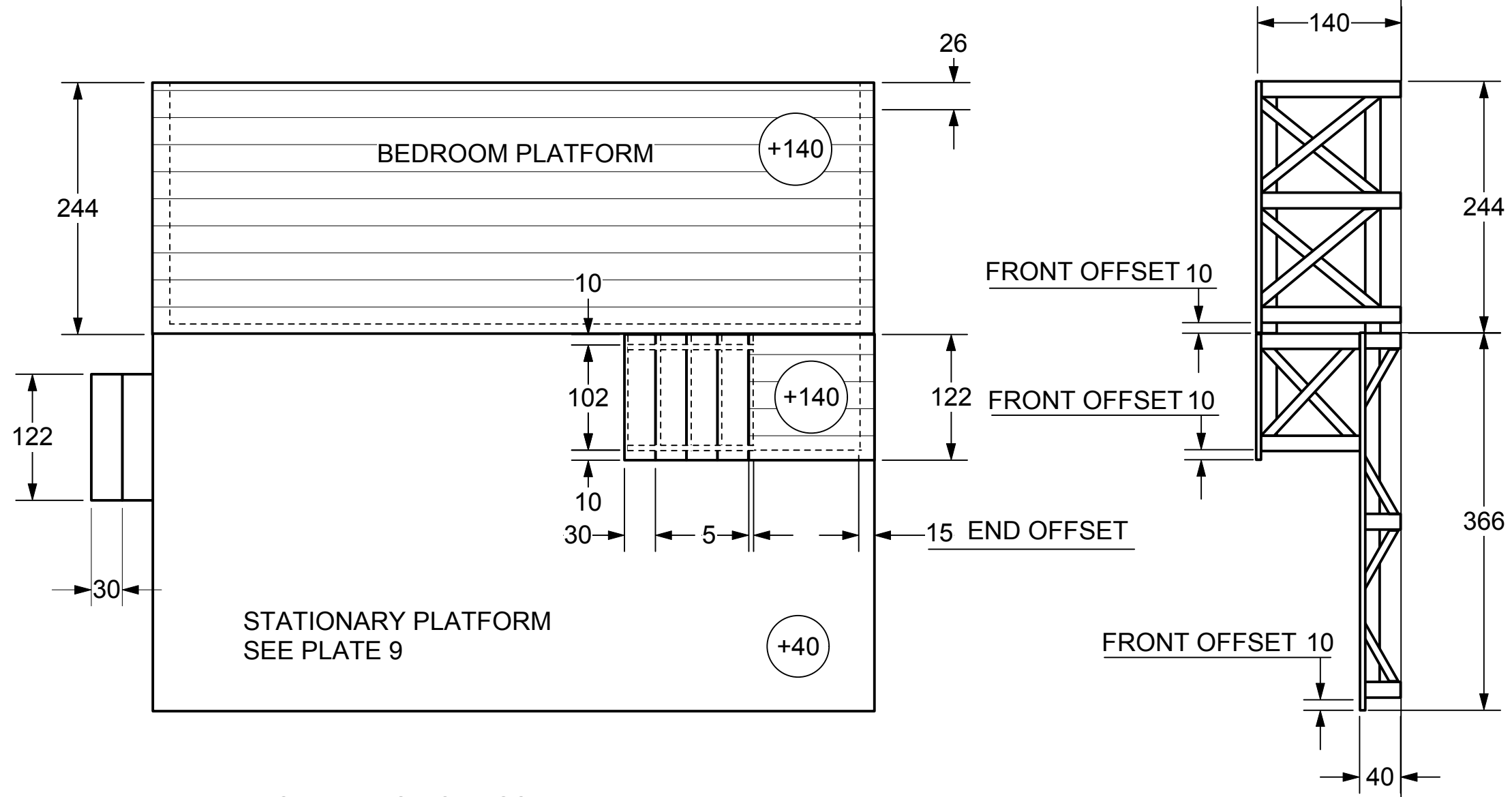

STAIR HAS NO LEGS
CONNECTS TO LANDING

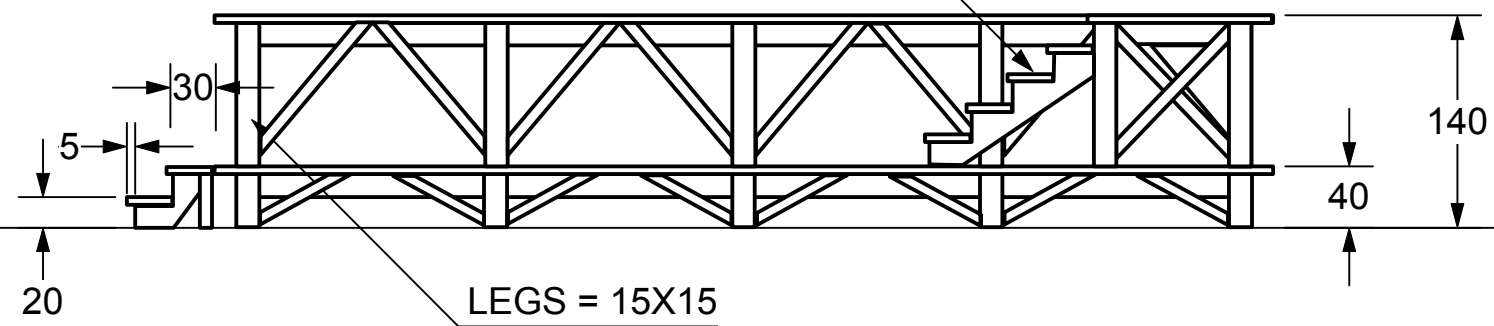

UPPER PLATFORMS

DATE: 27 SEPTEMBER 2015
SCALE: 1:50
PLATE 10

THE CRUCIBLE BY ARTHUR MILLER

AMERICAN UNIVERSITY IN CAIRO -- MALAK GABR THEATRE
DIRECTOR: FRANK BRADLEY
DESIGN: STANCIL CAMPBELL